



BENNINGER

**Bleaching
Solutions**

Woven Line

Leader in wet textile finishing

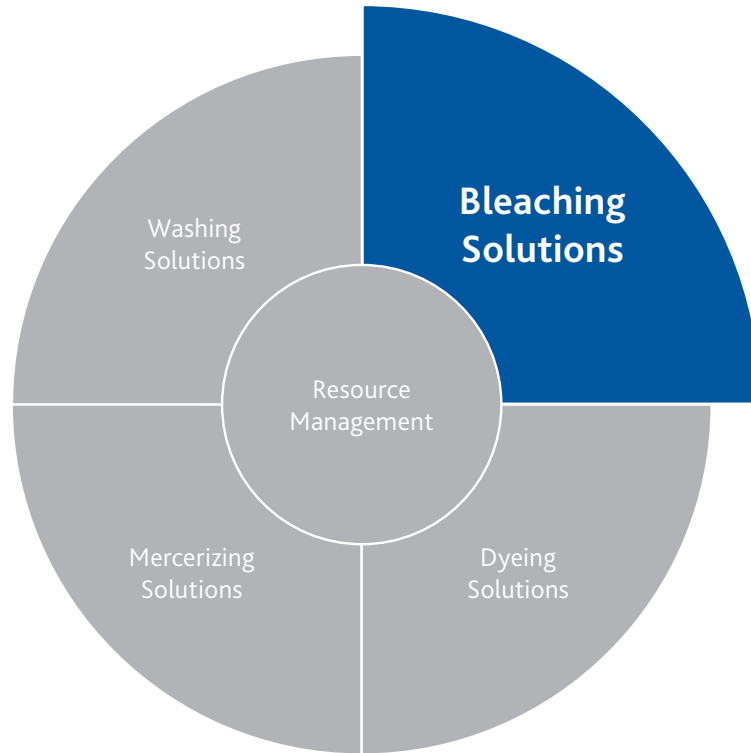

BEN-BLEACH

Continuous desizing and bleaching in one step

- High productivity
- Best pre-treatment results
- 30% lower production costs



BEN-WASH

The complete range for all washing processes

- Excellent washing performance
- Minimum water consumption
- High energy efficiency
- Up to 50% water and steam savings in comparison to the exhaust process



BEN-COLOR

The complete program for continuous and CPB dyeing

- High reproducibility
- Even dyeing results
- Low energy and water consumption
- High fastness properties
- No salt



BEN-DIMENSA

Highest quality mercerizing and caustification for maximum luster, dimensional stability and dye yield

- Improved dimensional stability
- Higher dye yield
- High luster
- For woven fabric and knitwear
- Silky, soft feel



BEN-ECO

Environmental protection and cost savings by recovering energy and resources

- Caustic recovery systems
- Heat recovery
- Waste water recycling und "zero discharge" solutions
- Energy-efficient drive technology
- CO₂ reductions by the use of the latest technologies

Customized textile solutions

Mission

Customized

Benninger supplies tailored process solutions with innovative and reliable products as well as comprehensive know-how in textile process engineering, always based on close collaboration and communication with our clients.

Textile

Our concepts are fully geared to the textile applications of our customers. With its many years of experience and comprehensive textile competence, Benninger creates long-term added value for its customers. Benninger is backed by a large number of reference installations for each of the individual applications.

Solutions

Benninger is an integral solution provider. We plan and implement technologically optimized and individual process and system solutions. We are a trustworthy and reliable partner throughout the entire life cycle of the plant.

Sustainability

For Benninger, assuming responsibility is a matter of course. We are committed to sustainability – for example by investing in the development of high-quality products as well as ecologically efficient processes. We actively save water, energy, chemicals and we also focus on recycling waste water, exhaust heat and valuable materials. Integral consideration of the relevant factors is equally as important to us as the balance between ecological and economic concerns.

With regard to sustainability, Benninger has central obligations. Wherever possible we work with maximum environmental awareness and conserve resources. We are aware of our social responsibility towards communities, consumers and our employees. We continuously improve our economic performance and support the sustainability aims of our customers.

Customer benefits

Our clients do not need products, they need solutions. At Benninger, customer benefits and needs are the central focus of all activities. High quality, process know-how, many years of specialist competence, unique application know-how, local availability and flexibility make us a reliable solution provider for the textile industry.

Our range of goods and services is continuously optimized and supplemented. We have tremendous innovative power, a high level of specialist and process expertise and have installed a large number of systems. New findings are continuously included into the development of solutions – always with the aim of enhancing the success of our customers. We improve the entire value-added chain of our customers by observing the process life cycles, and with quality products and a comprehensive range of services guarantee efficient and reliable plant operation.

Tradition

The future is rooted in the past. There is hardly anything more important than one's own history, as the innovations and business relationships of today and tomorrow are founded on the experience and know-how gained in the past. Benninger has been a global benchmark for competence and outstanding performance in wet textile finishing for more than 150 years. We always feel bound to our cultivated tradition of continually improving our services, products and processes so that the Benninger brand will continue to stand for quality, reliability and vision in the future.

As a company with international operations we are proud to support our customers on a basis of partnership and carry Swiss values such as high quality, reliability and trustworthiness out into the world.



One-step bleaching system for elastic woven fabric

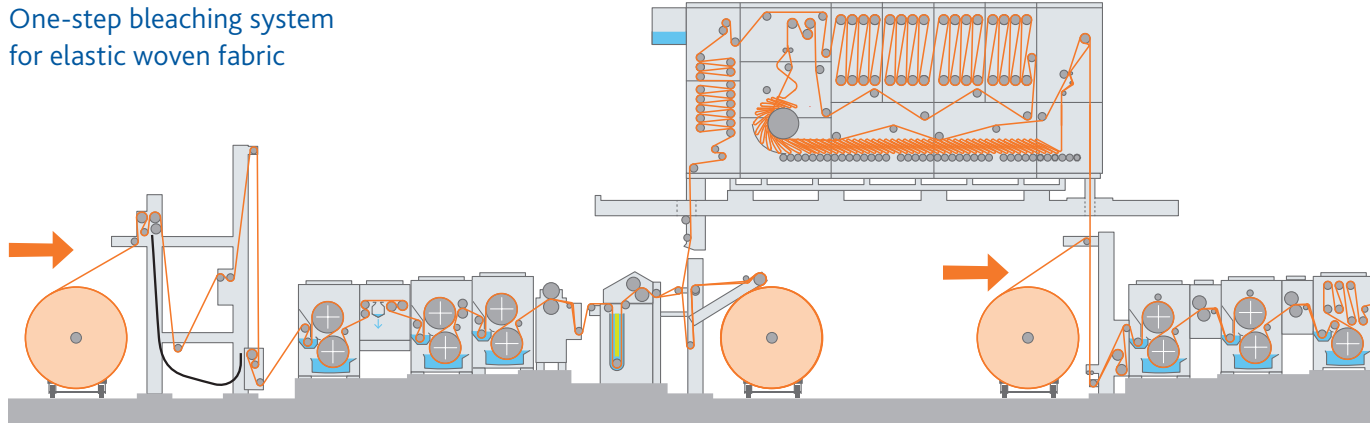

Pre-washing, desizing, PAD-STEAM combined bleaching, Option for cold bleaching, relaxation of elastic woven fabric, drying

Crease-free and low-tension fabric transport, controlled chemical impregnation, high flexibility

One-step bleaching system with singeing machine and continuous desizing

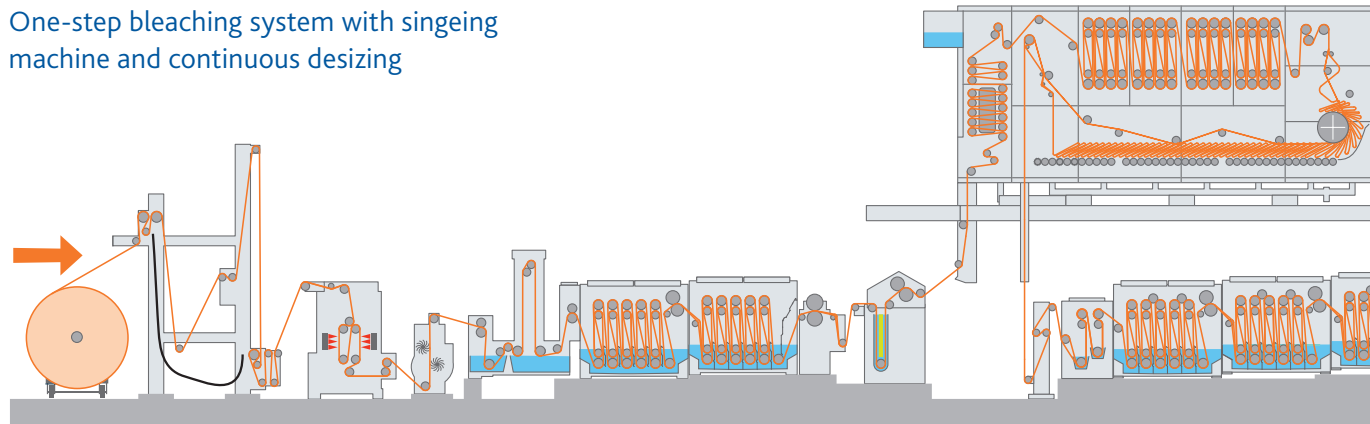

Singeing, continuous desizing, PAD-STEAM combined bleaching, drying

Fully-continuous desizing and bleaching, controlled chemical impregnation, high washing efficiency

Three steps bleaching system for woven fabric

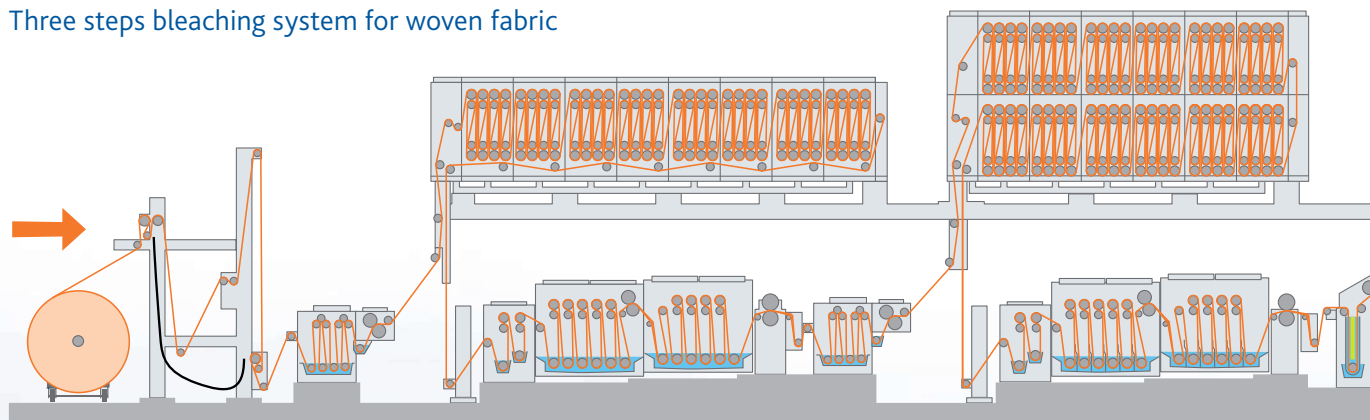

PAD-STEAM desizing, alkaline scouring, PAD-STEAM peroxide bleaching

Excellent pre-treatment effects (whiteness, absorbency) High productivity Controlled chemical impregnation

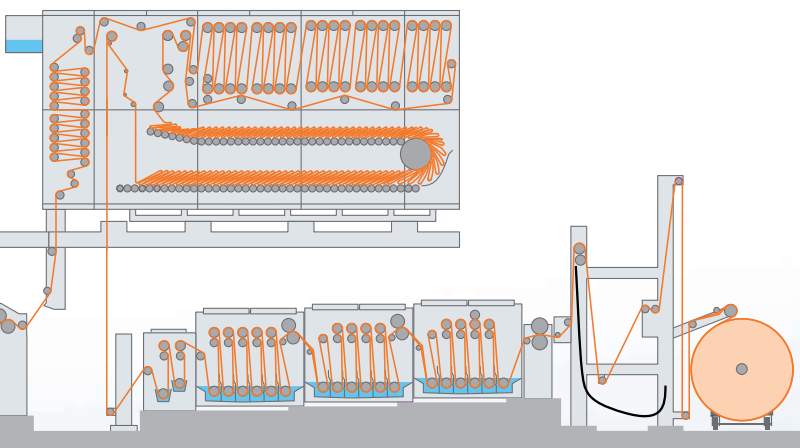
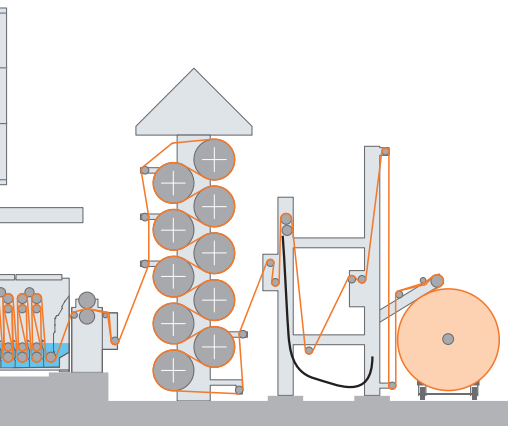
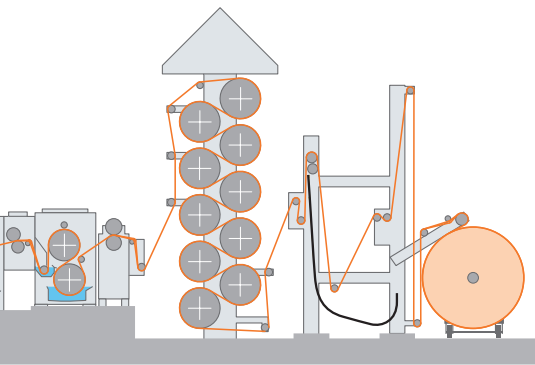

FACTS

- Modular design
- Suitable for all types of woven fabrics
- Crease-free fabric transport
- Low water and energy consumption
- High productivity of up to 150 m/min

INJECTA

Speedy swelling for optimised contaminant solubilisation

Pre-swelling unit
for all desizing processes

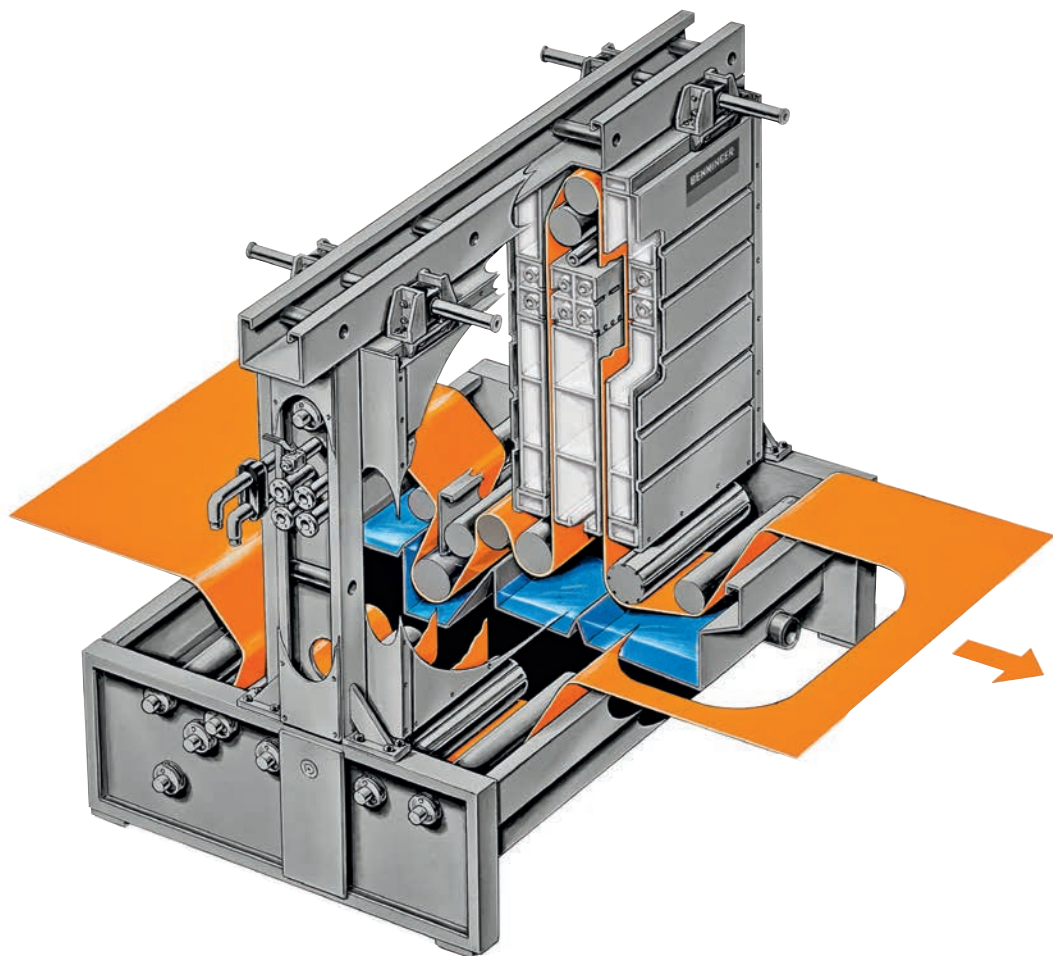

FACTS

- High mechanical washing efficiency due to steam injection
- Ideal washing unit for swelling and solubilization of high-viscosity substances
- Ideal for size recycling due to high partial flow concentration
- Can be combined with all Benninger washing units

FORTRACTA

Effective pre-washing for removal of surface contaminants

Prewashing unit

A further development of the proven Benninger duct washing technology for removing surface contaminants

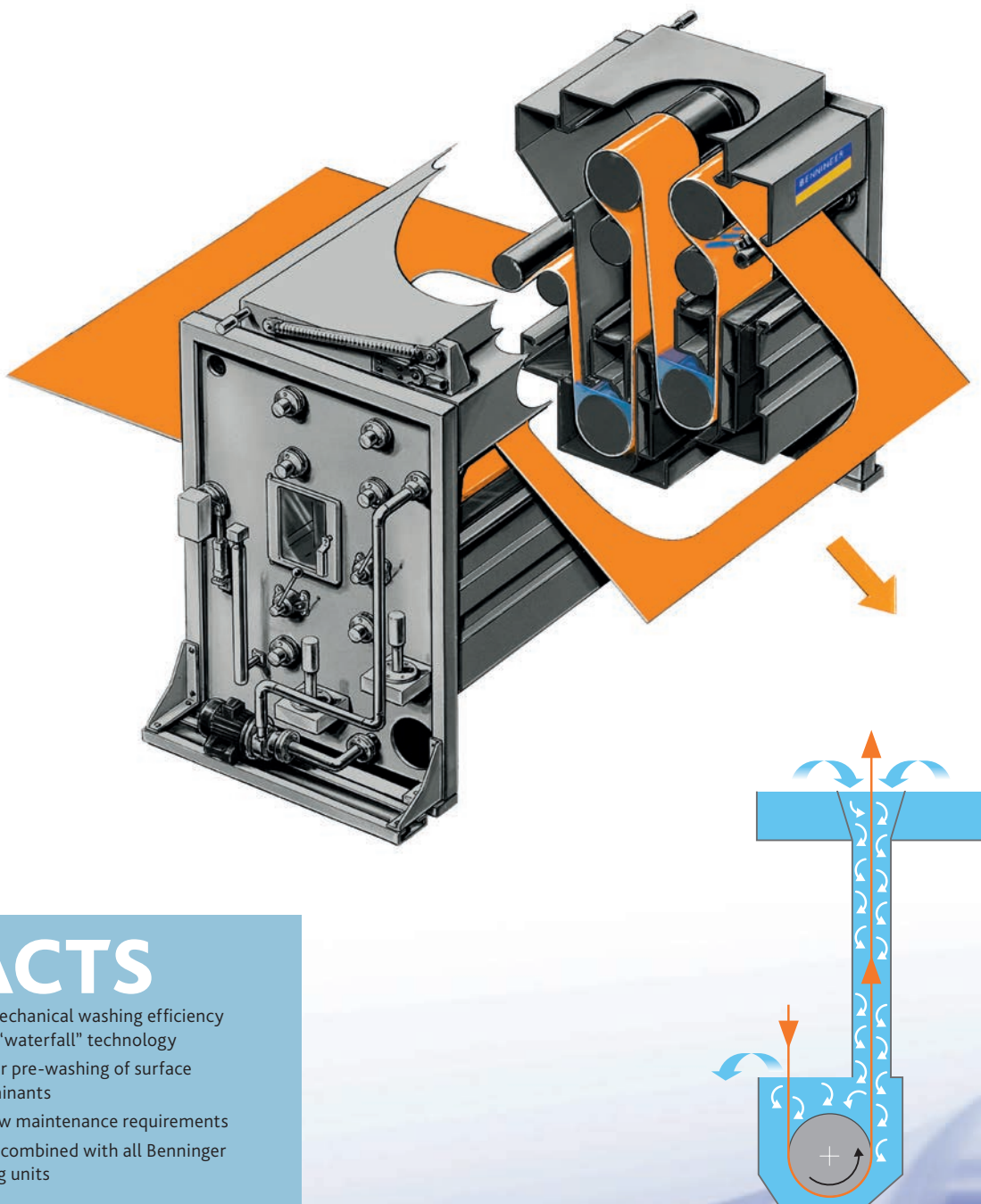

FACTS

- High mechanical washing efficiency due to "waterfall" technology
- Ideal for pre-washing of surface contaminants
- Very low maintenance requirements
- Can be combined with all Benninger washing units

EXTRACTA

High washing efficiency due to the multi-chamber system

Roller vat washing compartment for woven fabric

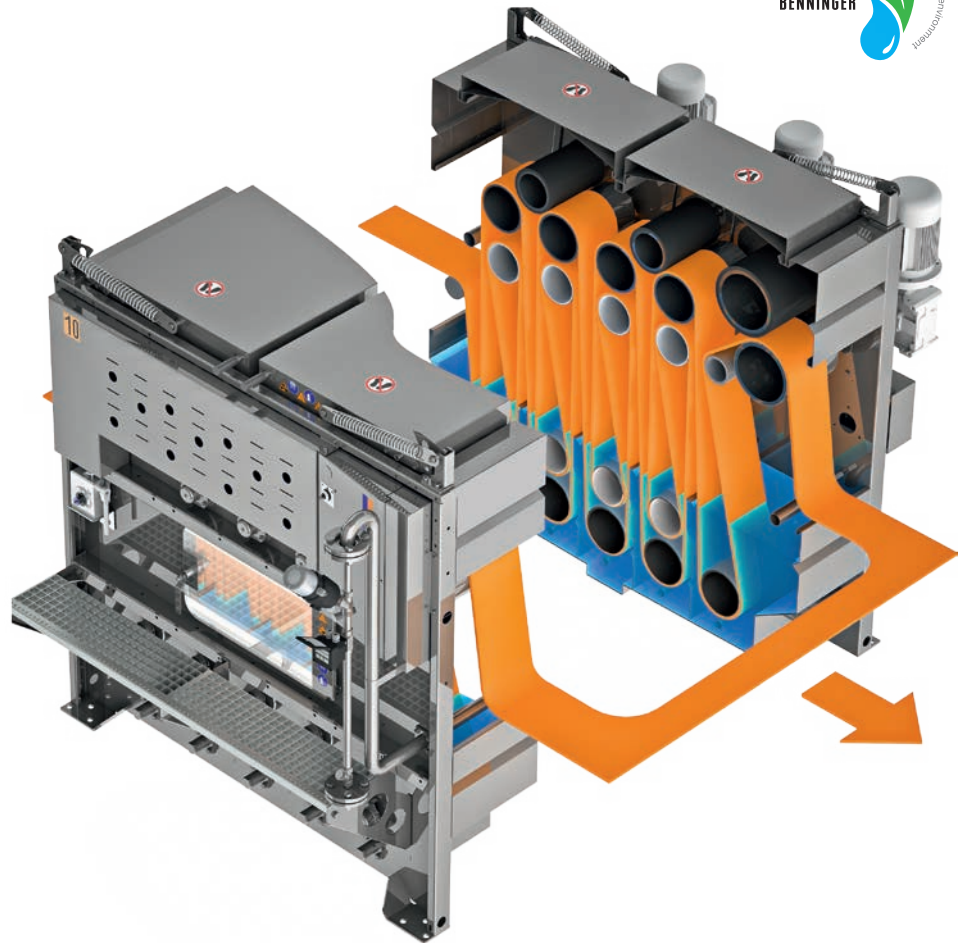

Counterflow principle

The meander counterflow configuration permits a concentration gradient. The washing process is divided into several washing steps that are repeated. The washing results can therefore be calculated on the basis of models and guaranteed.

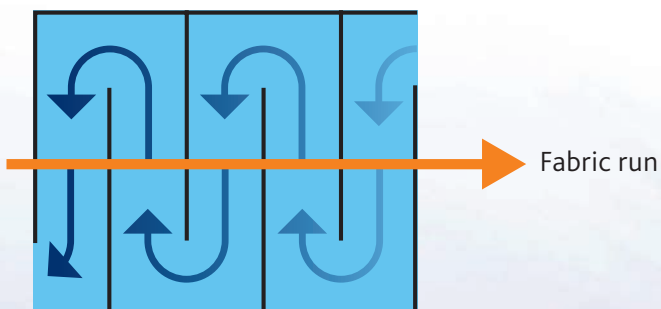

FACTS

- Washing in repeatable steps with liquor separation
- Calculable washing effect
- Low water and energy consumption
- Crease-free fabric run
- Steamtight
- Can be used for all high-performance washing tasks and also combined with waste water recycling or partial flow disposal
- Can be combined with all Benninger washing units

TRIKOFLEX

Efficient washing of
tension-sensitive textiles

Drum washing compartment
for elastic and technical fabrics

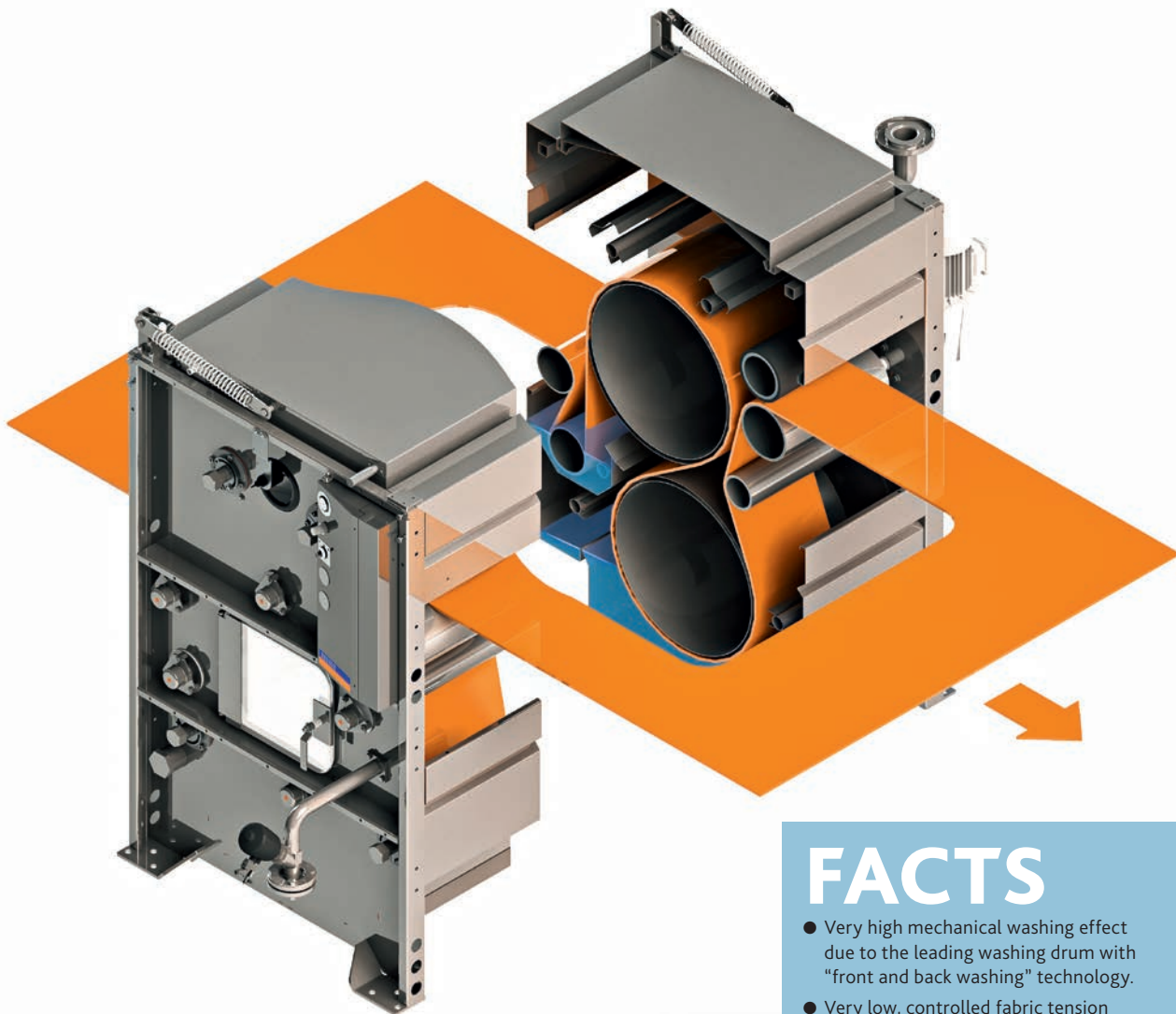

FACTS

- Very high mechanical washing effect due to the leading washing drum with "front and back washing" technology.
- Very low, controlled fabric tension
- Very low water and steam consumption thanks to counter-flow washing technology
- Crease-free fabric transport, also with sensitive fabrics
- Controlled relaxation of synthetic and elastane fibres
- Specially developed overflow weir for washing out spinning oils
- Can be combined with all Benninger washing units

IMPACTA LI

Penetration instead of addition

Impregnation module

for fabrics that are difficult to impregnate

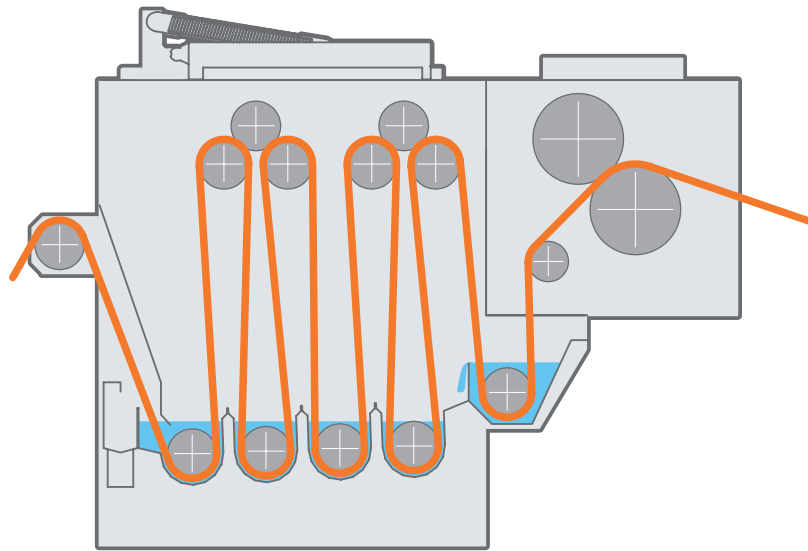

Chemical metering system

Proportional and "just-in-time" to the fabric throughput

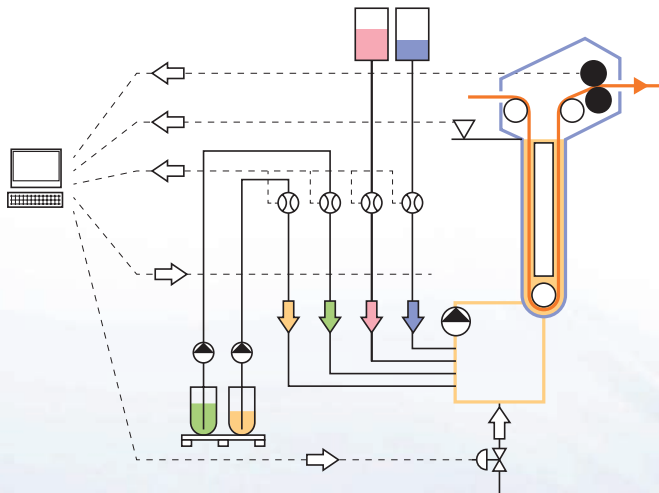

FACTS

- Controlled, adjustable liquor application
- Very good penetration into the fibre core
- For high production speeds and heavy articles
- Exact chemical quantity on the fabric
- Automatic chemical metering system

IMPACTA AP

Reproducible impregnation with controlled liquor application

Impregnation module

solves all impregnation tasks for the bleaching process

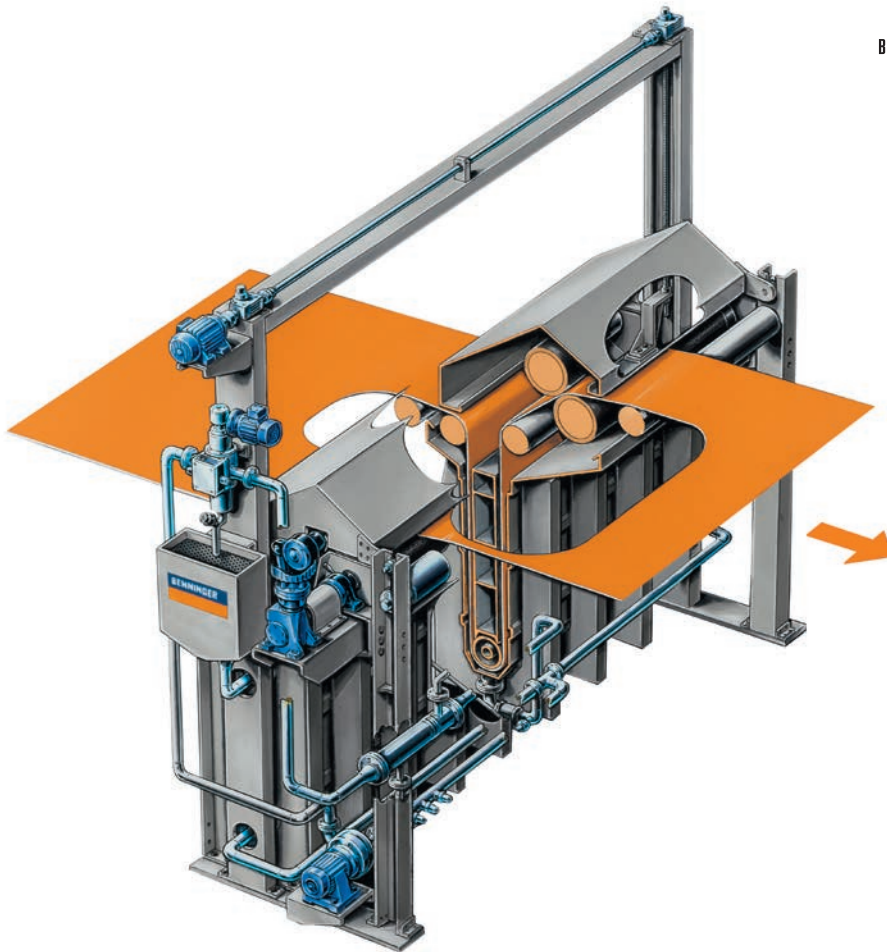

FACTS

- Controlled, adjustable liquor application
- Low liquor content
- For medium production speeds and medium-heavy articles
- Exact chemical quantity on the fabric
- Automatic chemical metering system

REACTA

Reaction process under reproducible conditions

Combined bleaching steamer

Correct fabric guidance and optimum dwelling times for all applications

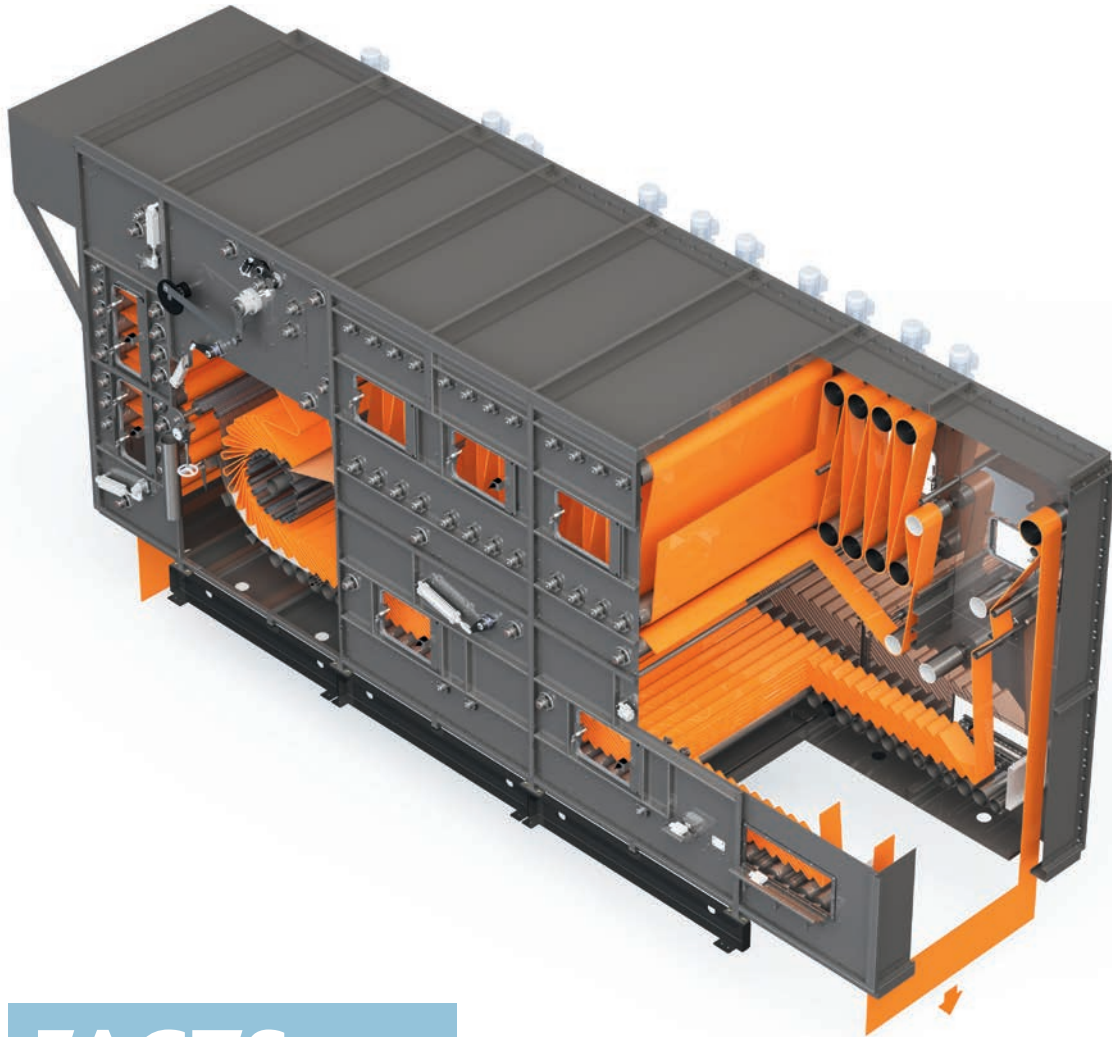

FACTS

- Dwelling times of 4 to 40 minutes
- External steam generation (no catalytic damage)
- Tight strand fabric run for crease sensitive woven fabrics
- Automatic changeover at the push of a button
- Plaiter for controlled loop formation
- Reversing drum for controlled staple turning
- Large roller diameter and low distances
- Modular design for perfect customizing

REACTA

Can be configured for all requirements

Combined bleaching steamer

Variation for all applications

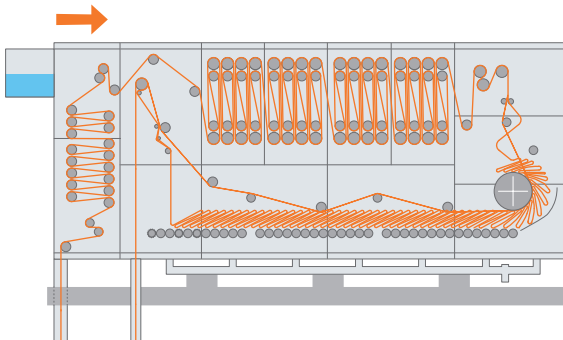

Combi-steamer with single roller bed
Dwelling time: 3–45 minutes

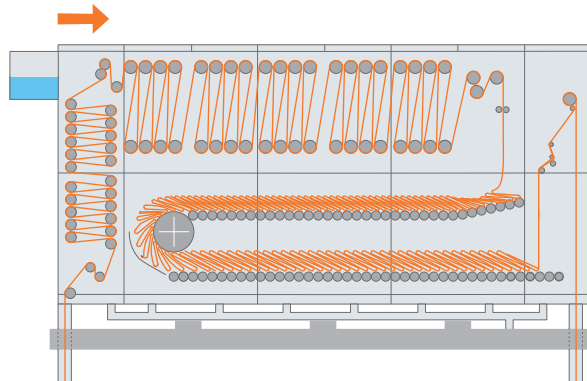

Combi-steamer with double roller bed
Dwelling time: 5–60 minutes

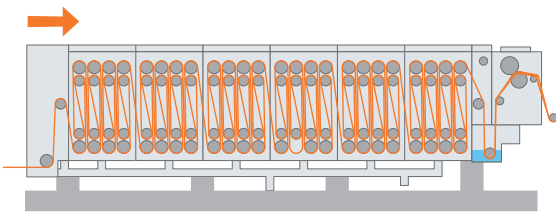

Shock-steamer
25–200 m fabric content

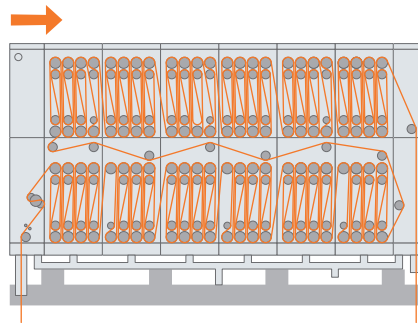

Shock-steamer, multi-layer
80–320 m fabric content

WHAT ARE THE BENNINGER ADVANTAGES?

Benninger – your partner for textile finishing!

Technological competence

Benninger is distinguished by its comprehensive process know-how in both application consulting and project planning as well as by its close communication with customers throughout the entire life cycle of the installed plants. With its focus on engineering and a high standard of technical competence, Benninger is a recognized global pioneer in technology.

- High technology and application expertise
- Process consulting and project planning
- Sustainable resource management
- Carbon footprint
- Best available techniques (BAT)

System solutions

As the leader in its line of technology, Benninger provides competent advice and supplies innovative and effective product solutions to the required quality standard by the agreed deadline for a fair market price, backed by reliable, first class customer service.

- Complete product range (woven and knit)
- High process reliability and lower operating costs
- Performance guarantee / Payback calculation
- Technology trends and product innovation
- Premium-quality OEM components

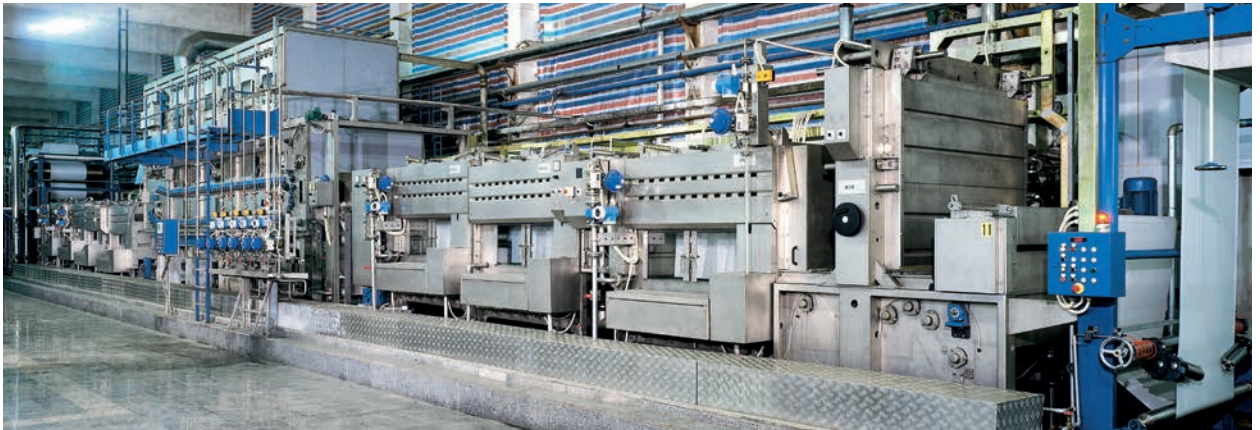

After-sales service – full service

With Benninger you are always in good hands. Specialists are always at your disposal at the Benninger service centers and provide competent, prompt customer service. Regular maintenance by expert technicians minimizes unexpected downtimes and, as experienced instructors, they pass on their know-how. In addition, the specialized spare parts service team guarantees fast and reliable supply of original Benninger spare parts, rounding off the range of Benninger services.

- Customer-oriented service solutions
- Preventative maintenance (service contracts)
- Fast on-site service
- Competent help desk (software and hardware)
- Technical audits
- Customized modernization solutions
- Original Benninger spare parts (warranty)
- Customer training

Development cooperation and partnerships

Benninger is distinguished by its process and customer orientation, focus on the demands of the market and its customers, as well as continuous and systematic improvement. All this ensures customer confidence and satisfaction. Benninger – your partner for textile finishing!

- High specialist competence
- Consistent customer orientation
- Reliability and integrity
- Local representation in strategic markets
- Large number of reference installations
- Excellent reputation and long-standing customer relationships
- Goal-oriented development cooperation

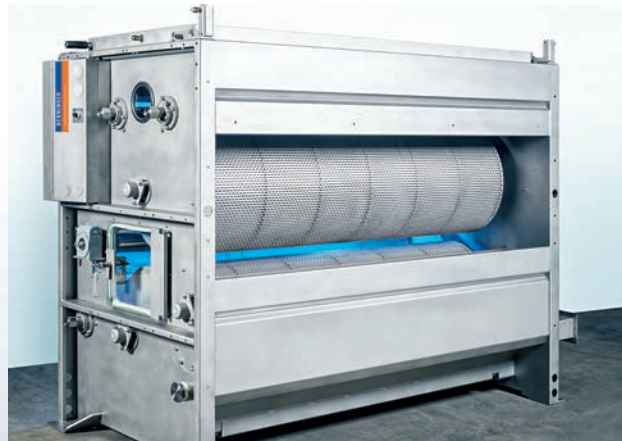

BENNINGER

Headquarters

Switzerland
Benninger AG
 9240 Uzwil, Switzerland
 T +41 71 955 85 85
 F +41 71 955 87 47
info@benningergroup.com



China
Suzhou Benninger Küsters
Machinery Co. Ltd.
 Suzhou City, Jiangsu Province
 215151 P.R. China
 T +86 512 8518 0380
 F +86 512 8518 0381
benchina@benningergroup.com

India
Benninger India
Private Ltd.
 Mumbai 400 014, India
 T +91 22 2417 5361
 F +91 22 2417 5362
benindia@benningergroup.com

Germany
Benninger Zell GmbH
 79669 Zell i.W., Germany
 T +49 7625 131 0
 F +49 7625 131 298
tirecord@benningergroup.com

Germany
Küsters Textile GmbH
 02763 Zittau, Germany
 T +49 3583 83 0
 F +49 3585 83 303
kuesters@benningergroup.com